

regga P2

Your Rega **P2** turntable has been designed to effectively reproduce music whilst being easy to use. We have omitted all the usual gimmicks; concentrating the manufacturing costs on the high quality and design necessary to reproduce records accurately. Using a manual speed change rather than an automatic mechanism, eliminates speed inconsistencies and possible damage to the drive belt. The money we save with this method is spent on an expensive low vibration motor which would normally be used on a turntable costing two or three times the amount. Rega's simplistic design and the use of extremely high quality components ensure that your turntable should last for many years. The tips we give may help increase the longevity of your P2 and give you maximum musical enjoyment combined with ease of use.

With the cartridge fitted and aligned using the protractor supplied, ensure that the bias adjustment slider is set to zero. Screw the balance weight along its shaft until the stylus is "floating" just 1mm clear of the record.

The recommended tracking force can now be applied by rotating the balance weight so that it moves towards the front of the arm. A half turn gives 1g tracking force. Always use a force which corresponds to the upper limit of the cartridge maker's recommended range.

Set the bias adjustment slider to the same number as the tracking force control.- I.e. 1.5 g tracking force = 1.5 on the bias slider.

Speed control

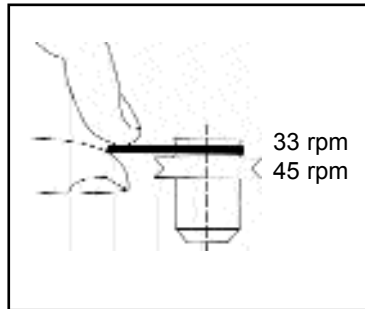

Top view of turntable

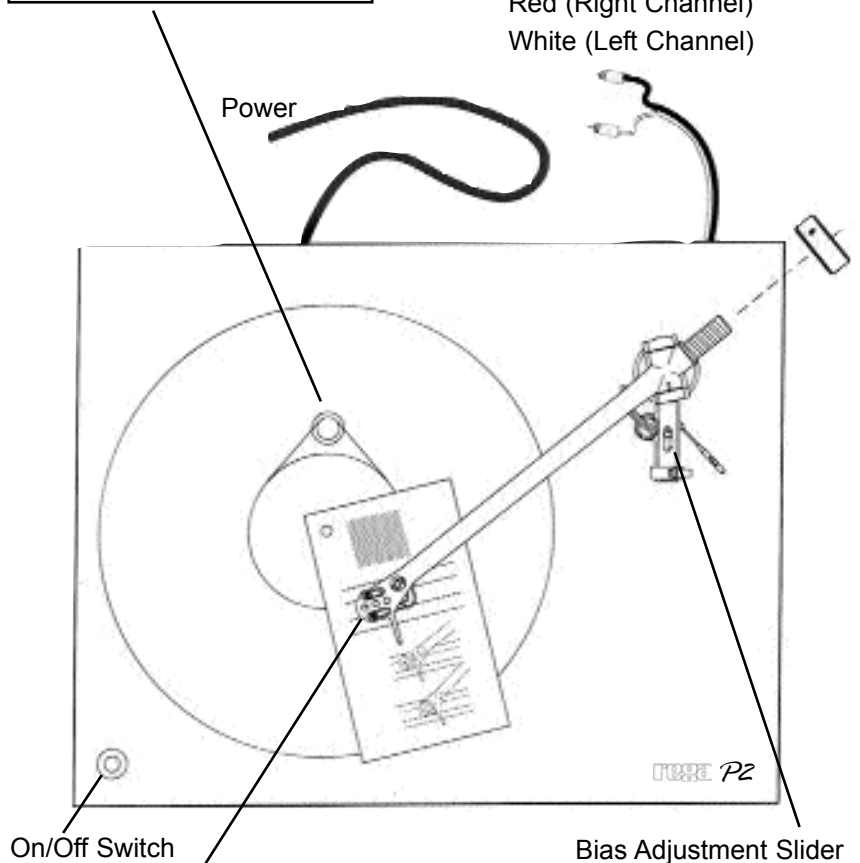

Cartridge connections

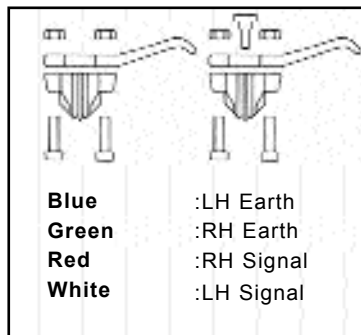

Set up guide

The stylus must line up with the front edge of the hole

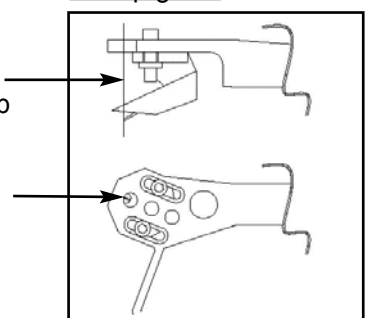

Hints and Tips using your Turntable

- 1 Mount the turntable on a rigid, level surface. A light shelf or turntable support screwed to a wall or in an alcove is ideal. Avoid mounting on hollow or heavy cabinets or anything mounted on a wooden floor.
- 2 Try to keep the lid closed while playing the records. This will prevent dust falling on to the records and make cleaning unnecessary. There may also be a sonic improvement.
- 3 Don't use any record cleaner that works while the record is playing or any cleaners that use water or solvents. If you keep your records stored in their sleeves, avoid touching the playing surfaces, play with the lid down and keep all water and fluids away, cleaning should not be necessary. Don't worry about visible dust on the record surface, this is brushed aside by the stylus and any that collects on the stylus can be easily blown away. In general, record cleaning is overdone and one should not believe all the claims made by record cleaner manufacturers.
- 4 Leave the turntable running during a record playing session. Switch on before the session and only switch off after you have finished.
- 5 Don't lift the centre hub out from the main bearing. The bearing is factory assembled with a film of special thick lubricant. If the centre hub is removed this film may be disturbed.
- 6 **Rega** turntables are designed to optimise performance for music reproduction and therefore no compromises have been made to give quick start times. The normal time taken for full speed to be reached is between 2-5 seconds.
- 7 The arm earth (or ground) is automatically connected through the arm cable screening. No other earthing should be necessary.
- 8 Save the original packing in case you ever need to transport the turntable.
- 9 Don't use any polishes on the turntable or lid. To clean or dust, wipe gently with a soft cotton duster (slightly damp only if necessary).
- 10 Should you experience any problem with your turntable or wish to enquire about servicing please contact your **Rega** dealer.

Warning: Any attempt to adjust or repair this product by persons other than **Rega** personnel may invalidate the guarantee.

